



XYG-QD 系列 铜制气动管接头

XYG-QD Copper pneumatic piping connector

SINYA



目 录

CONTENT

- | | | | | | | | |
|---|----|---|-------------------------------------|---|----|---|--------------------------------------|
|  | 04 |  | -QD1型直通终端接头
Straight Connector |  | 08 |  | -QD4型四通中间接头
Cross Union |
|  | 04 |  | -QD6型直通中间接头
Straight Union |  | 08 |  | -QD01型外套螺母
Cap Nut |
|  | 04 |  | -QD61型直通穿板接头
Straight Bulkhead |  | 09 |  | -QD02型密封圈
Sealing Ring |
|  | 05 |  | -QD7型压力表直通接头
Gauge Connector |  | 09 |  | -QD03型薄壁衬套
Thin Bushing |
|  | 05 |  | -QD2型弯通终端接头
Elbow Connector |  | 09 |  | -QDFP1型直通终端接头
Straight Connector |
|  | 06 |  | -QD9型弯通中间接头
Elbow Union |  | 10 |  | -QDFP7型内螺纹直通终端接头
Female Connector |
|  | 06 |  | -QD62型弯通穿板接头
Elbow Bulkhead |  | 10 |  | -QDFP6型直通中间接头
Straight Union |
|  | 06 |  | -QDTTM型外螺纹支管三通接头
Male Branch Tee |  | 10 |  | -QDFP2型弯通终端接头
Elbow Connector |
|  | 07 |  | -QDMFT型调节三通接头
Adjustable Tee |  | 10 |  | -QDFP62型弯通穿板接头
Elbow Bulkhead |
|  | 07 |  | -QDTTF型压力表三通接头
Gauge Tee |  | 11 |  | -QDFP3型三通中间接头
Tee Union |
|  | 08 |  | -QD3型三通中间接头
Tee Union |  | 11 |  | -QDFPTFT型压力表三通接头
Gauge Tee |
| | | | |  | 11 |  | -QDFPTMT型三通终端接头
Tee Connector |
| | | | |  | 11 |  | -QDFP04型螺母
Nut |

XYG — QD Copper pneumatic piping connector

● 技术说明

QD系列铜制气动管接头（卡箍式管接头），适用于气源管路的连接，将气源信号输送至气动仪表，气动装置等场合。配管材料适用于紫铜管、尼龙管、PU管、塑料管等。管接头材料为黄铜表面镀铬、镀镍两种，配管外径公制 $\Phi 3\text{mm} \sim \Phi 12\text{mm}$ 及英制 $1/8\text{in} \sim 1/2\text{in}$ ，公称压力 $\leq 1.6\text{MPa}$ 。该系列产品广泛使用在炼油、化工、轻工、纺织、生物化工、医药等气动控制领域。它具有连接可靠，密封性和重复性好，安装检修极其方便，工作效率高，安全可靠性好等优点。

● Technical Description

QD series Copper pneumatic tube fittings (fittings with slip-collar) are applicable to connect the air-supplying tubes. They are used to convey the air-supplying signals to the pneumatic instruments or devices. The tubes would be made of copper, nylon, PU or plastics. The tube fittings can be made of brass plated with chromium or nickel with the tube outside diameter $\Phi 3\text{mm} \sim \Phi 12\text{mm}$ in metric or $1/8\text{in} \sim 1/2\text{in}$ in British. The nominal pressure would be no more than 1.6MPa . The products have been widely used in the pneumatic-controlling fields of oil-refining, chemical industry, light industry, textile industry, bio-chemical industry, medicine and etc. The products have many advantages, such as: reliable connecting, good sealing features & repetition, easy to install and maintain, high operation efficiency, good safety & stability.

● 工作原理图

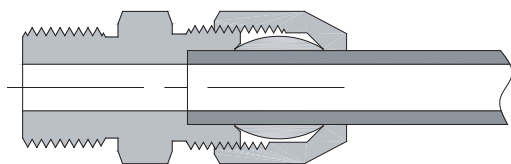

密封圈工作前 Before sealing ring functions

卡箍式管接头其工作原理：密封圈在螺母的作用下，密封圈边缘与接头体内锥面产生变形，使密封圈边缘与导管径向收缩抱紧导管，起到密封作用。（使用尼龙管、PU管时必须使用薄壁衬套）。

● Working Principle

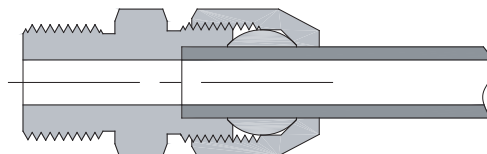

密封圈工作后 After sealing ring functions

Working principle of the tube fittings with slip-collar is as following: the conical surface between the sealing ring edge and the body would become deformed after it is functioned by the nut. The ring edge would clamp the conduit vertically tightly for sealing (The thin bushing should be used for nylon and PU tubes).

● -QD1型直通终端接头 Straight Connector

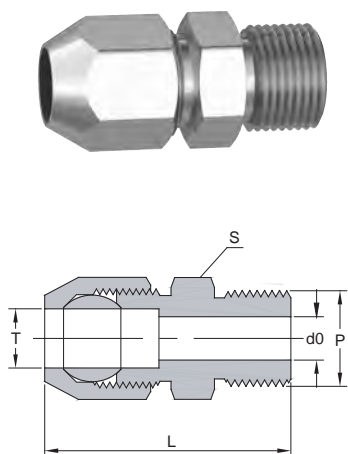

基本订货号 Order information	T (mm)	P	d0		L		S	
			英寸 (in)	毫米 (mm)	英寸 (in)	毫米 (mm)	英寸 (in)	毫米 (mm)
-QD1-3mm-M8	3	M8 × 1	0.08	2	1.10	28	0.47	12
-QD1-4mm-M10	4	M10 × 1	0.12	3	1.18	30	0.55	14
-QD1-6mm-M10	6	M10 × 1	0.16	4	1.26	32	0.55	14
-QD1-6mm-M12	6	M12 × 1	0.16	4	1.34	34	0.67	17
-QD1-8mm-M12	8	M12 × 1	0.24	6	1.34	34	0.67	17
-QD1-8mm-M14	8	M14 × 1.5	0.24	6	1.42	36	0.75	19
-QD1-8mm-M16	8	M16 × 1.5	0.24	6	1.42	36	0.75	19
-QD1-10mm-M14	10	M14 × 1.5	0.31	8	1.42	36	0.75	19
-QD1-10mm-M16	10	M16 × 1.5	0.31	8	1.42	36	0.75	19
-QD1-12mm-M18	12	M18 × 1.5	0.39	10	1.50	38	0.87	22
-QD1-12mm-M20	12	M20 × 1.5	0.39	10	1.57	40	0.94	24
-QD1-4mm-2	4	NPT1/8	0.12	3	1.18	30	0.47	12
-QD1-6mm-4	6	NPT1/4	0.16	4	1.26	32	0.55	14
-QD1-8mm-6	8	NPT3/8	0.24	6	1.26	32	0.67	17
-QD1-10mm-6	10	NPT3/8	0.31	8	1.34	34	0.67	17
-QD1-12mm-8	12	NPT1/2	0.39	10	1.54	39	0.87	22

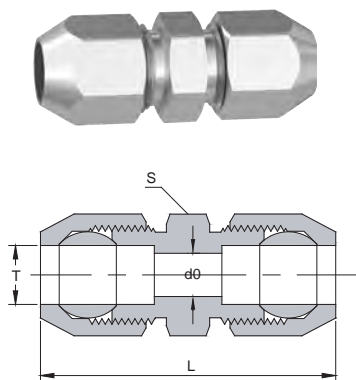

● -QD6型直通中间接头 Straight Union

基本订货号 Order information	T (mm)	d0		L		S	
		英寸 (in)	毫米 (mm)	英寸 (in)	毫米 (mm)	英寸 (in)	毫米 (mm)
-QD6-3mm	3	0.08	2	1.34	34	0.39	10
-QD6-4mm	4	0.12	3	1.50	38	0.39	10
-QD6-6mm	6	0.16	4	1.65	42	0.47	12
-QD6-8mm	8	0.24	6	1.65	42	0.55	14
-QD6-10mm	10	0.31	8	1.77	45	0.67	17
-QD6-12mm	12	0.39	10	1.85	47	0.75	19

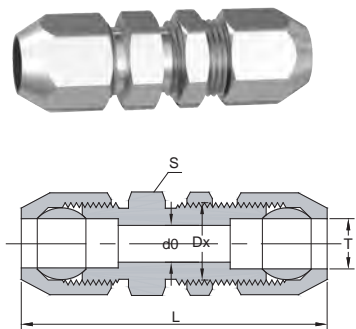

● -QD61型直通穿板接头 Strdight Bulkhead

基本订货号 Order information	T (mm)	d0		L		S		Dx	
		英寸 (in)	毫米 (mm)	英寸 (in)	毫米 (mm)	英寸 (in)	毫米 (mm)	英寸 (in)	毫米 (mm)
-QD61-3mm	3	0.08	2	1.89	48	0.39	10	0.33	8.5
-QD61-4mm	4	0.12	3	1.97	50	0.39	10	0.33	8.5
-QD61-6mm	6	0.16	4	2.05	52	0.47	12	0.41	10.5
-QD61-8mm	8	0.24	6	2.05	52	0.55	14	0.49	12.5
-QD61-10mm	10	0.31	8	2.17	55	0.67	17	0.57	14.5
-QD61-12mm	12	0.39	10	2.24	57	0.75	19	0.65	16.5

XYG-QD系列铜制气动管接头

XYG — QD Copper pneumatic piping connector

● -QD7型压力表直通接头 Gauge Connector

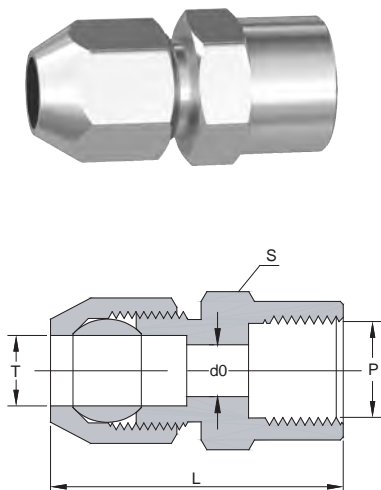

基本订货号 Order information	T (mm)	P	d0		L		S	
			英寸 (in)	毫米 (mm)	英寸 (in)	毫米 (mm)	英寸 (in)	毫米 (mm)
-QD7-6mm-M10	6	M10 × 1	0.16	4	1.34	34	0.55	14
-QD7-6mm-M14	6	M14 × 1.5	0.16	4	1.50	38	0.75	19
-QD7-6mm-M16	6	M16 × 1.5	0.16	4	1.50	38	0.87	22
-QD7-6mm-M20	6	M20 × 1.5	0.16	4	1.54	39	0.94	24
-QD7-8mm-M14	8	M14 × 1.5	0.24	6	1.50	38	0.75	19
-QD7-8mm-M16	8	M16 × 1.5	0.24	6	1.50	38	0.87	22
-QD7-8mm-M20	8	M20 × 1.5	0.24	6	1.54	39	0.94	24
-QD7-10mm-M16	10	M16 × 1.5	0.31	8	1.54	39	0.87	22
-QD7-10mm-M20	10	M20 × 1.5	0.31	8	1.54	39	0.94	24
-QD7-12mm-M20	12	M20 × 1.5	0.39	10	1.57	40	0.94	24
-QD7-6mm-G4	6	G1/4	0.16	4	1.50	38	0.75	19
-QD7-6mm-G8	6	G1/2	0.16	4	1.54	39	1.06	27
-QD7-8mm-G4	8	G1/4	0.24	6	1.50	38	0.75	19
-QD7-8mm-G8	8	G1/2	0.24	6	1.54	39	1.06	27
-QD7-10mm-G8	10	G1/2	0.31	8	1.54	39	1.06	27
-QD7-12mm-G8	12	G1/2	0.39	10	1.54	39	1.06	27

● -QD2型弯通终端接头 Elbow Connector

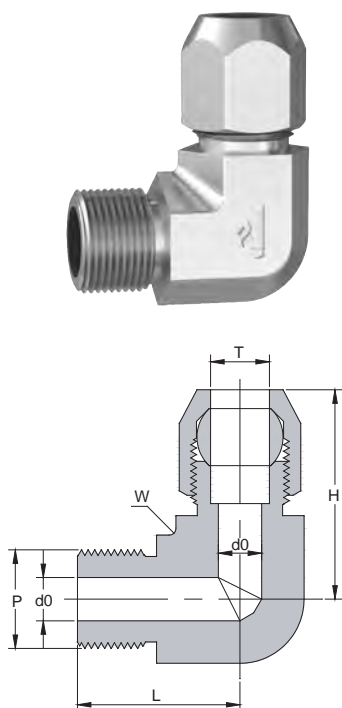

基本订货号 Order information	T (mm)	P	d0		L		H		W	
			英寸 (in)	毫米 (mm)	英寸 (in)	毫米 (mm)	英寸 (in)	毫米 (mm)	英寸 (in)	毫米 (mm)
-QD2-3mm-M8	3	M8 × 1	0.08	2	0.63	16	0.83	21	0.37	9.5
-QD2-4mm-M10	4	M10 × 1	0.12	3	0.75	19	0.91	23	0.56	14.2
-QD2-6mm-M10	6	M10 × 1	0.16	4	0.79	20	0.98	25	0.56	14.2
-QD2-6mm-M12	6	M12 × 1	0.16	4	0.79	20	0.98	25	0.69	17.5
-QD2-8mm-M12	8	M12 × 1	0.24	6	0.83	21	0.98	25	0.69	17.5
-QD2-8mm-M14	8	M14 × 1.5	0.24	6	0.91	23	1.06	27	0.69	17.5
-QD2-8mm-M16	8	M16 × 1.5	0.24	6	0.94	24	1.14	29	0.75	19.0
-QD2-10mm-M14	10	M14 × 1.5	0.31	8	0.91	23	1.18	30	0.69	17.5
-QD2-10mm-M16	10	M16 × 1.5	0.31	8	0.98	25	1.18	30	0.75	19.0
-QD2-12mm-M18	12	M18 × 1.5	0.39	10	1.18	30	1.26	32	0.82	20.8
-QD2-12mm-M20	12	M20 × 1.5	0.39	10	1.26	32	1.30	33	0.94	23.8
-QD2-4mm-2	4	NPT1/8	0.12	3	0.63	16	0.83	21	0.37	9.5
-QD2-6mm-4	6	NPT1/4	0.16	4	0.75	19	0.91	23	0.56	14.2
-QD2-8mm-6	8	NPT3/8	0.24	6	0.83	21	0.98	25	0.69	17.5
-QD2-10mm-6	10	NPT3/8	0.31	8	0.91	23	1.18	30	0.69	17.5
-QD2-12mm-8	12	NPT1/2	0.39	10	1.34	34	1.30	33	0.94	23.8

● -QD9型弯通中间接头 Elbow Union

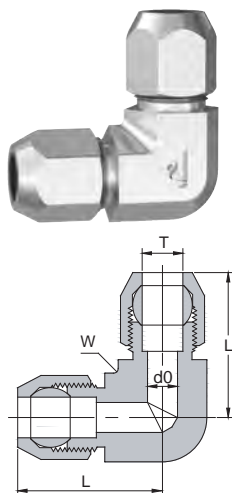

基本订货号 Order information	T (mm)	d0		L		W	
		英寸 (in)	毫米 (mm)	英寸 (in)	毫米 (mm)	英寸 (in)	毫米 (mm)
-QD9-3mm	3	0.08	2	0.83	21	0.37	9.5
-QD9-4mm	4	0.12	3	0.91	23	0.37	9.5
-QD9-6mm	6	0.16	4	1.02	26	0.50	12.7
-QD9-8mm	8	0.24	6	1.06	27	0.56	14.2
-QD9-10mm	10	0.31	8	1.14	29	0.69	17.5
-QD9-12mm	12	0.39	10	1.18	30	0.69	17.5

● -QD62型弯通穿板接头 Elbow Bulkhead

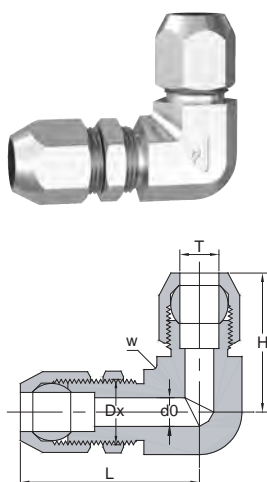

基本订货号 Order information	T (mm)	d0		L		H		W		Dx	
		英寸 (in)	毫米 (mm)	英寸 (in)	毫米 (mm)	英寸 (in)	毫米 (mm)	英寸 (in)	毫米 (mm)	英寸 (in)	毫米 (mm)
-QD62-3mm	3	0.08	2	1.42	36	0.83	21	0.37	9.5	0.33	8.5
-QD62-4mm	4	0.12	3	1.50	38	0.91	23	0.50	12.7	0.33	8.5
-QD62-6mm	6	0.16	4	1.57	40	1.02	26	0.50	12.7	0.41	10.5
-QD62-8mm	8	0.24	6	1.61	41	1.06	27	0.56	14.2	0.49	12.5
-QD62-10mm	10	0.31	8	1.65	42	1.14	29	0.56	14.2	0.57	14.5
-QD62-12mm	12	0.39	10	1.69	43	1.18	30	0.69	17.5	0.65	16.5

● -QDTTM型外螺纹支管三通接头 Male Branch Tee

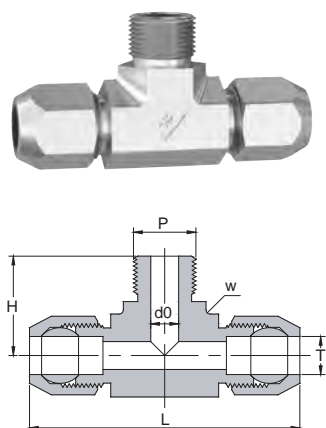

基本订货号 Order information	T (mm)	P	d0		L		H		W	
			英寸 (in)	毫米 (mm)	英寸 (in)	毫米 (mm)	英寸 (in)	毫米 (mm)	英寸 (in)	毫米 (mm)
-QDTTM-3mm-M8	3	M8 × 1	0.08	2	1.89	48	0.83	21	0.37	9.5
-QDTTM-4mm-M10	4	M10 × 1	0.12	3	1.89	48	0.91	23	0.56	14.2
-QDTTM-6mm-M10	6	M10 × 1	0.16	4	1.97	50	0.98	25	0.56	14.2
-QDTTM-6mm-M12	6	M12 × 1	0.16	4	2.05	52	0.98	25	0.69	17.5
-QDTTM-8mm-M14	8	M14 × 1.5	0.24	6	2.13	54	1.06	27	0.69	17.5
-QDTTM-8mm-M16	8	M16 × 1.5	0.24	6	2.13	54	1.14	29	0.75	19
-QDTTM-10mm-M14	10	M14 × 1.5	0.31	8	2.20	56	1.18	30	0.69	17.5
-QDTTM-10mm-M16	10	M16 × 1.5	0.31	8	2.20	56	1.18	30	0.75	19
-QDTTM-12mm-M18	12	M18 × 1.5	0.39	10	2.52	64	1.22	31	0.82	20.8
-QDTTM-12mm-M20	12	M20 × 1.5	0.39	10	2.52	64	1.26	32	0.94	23.8
-QDTTM-4mm-2	4	NPT1/8	0.12	3	1.97	50	0.83	21	0.37	9.5
-QDTTM-6mm-4	6	NPT1/4	0.16	4	2.13	54	0.91	23	0.56	14.2
-QDTTM-8mm-6	8	NPT3/8	0.24	6	2.20	56	0.98	25	0.69	17.5
-QDTTM-10mm-6	10	NPT3/8	0.31	8	2.20	56	1.18	30	0.69	17.5
-QDTTM-12mm-8	12	NPT1/2	0.39	10	2.60	66	1.30	33	0.94	23.8

XYG-QD系列铜制气动管接头

XYG — QD Copper pneumatic piping connector

● -QDMFT型调节三通接头 Adjustable Tee

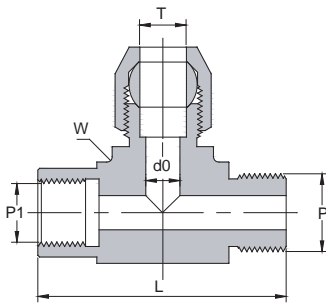

基本订货号 Order information	T (mm)	P	P1	d0		L		W	
				英寸 (in)	毫米 (mm)	英寸 (in)	毫米 (mm)	英寸 (in)	毫米 (mm)
-QDMFT-6mm-M14/M14	6	M14 × 1.5	M14 × 1.5	0.16	4	1.50	38	0.75	19
-QDMFT-6mm-M16/M14	6	M16 × 1.5	M14 × 1.5	0.16	4	1.50	38	0.75	19
-QDMFT-6mm-M16/M10	6	M16 × 1.5	M10 × 1	0.16	4	1.42	36	0.75	19
-QDMFT-6mm-M16/M16	6	M16 × 1.5	M16 × 1.5	0.16	4	1.50	38	0.87	22
-QDMFT-6mm-M14/M16	6	M14 × 1.5	M16 × 1.5	0.16	4	1.50	38	0.87	22
-QDMFT-6mm-4/M12	6	NPT1/4	M12 × 1.5	0.16	4	1.42	36	0.67	17
-QDMFT-6mm-8/M14	6	NPT1/2	M14 × 1.5	0.16	4	1.69	43	0.87	22
-QDMFT-8mm-M16/M14	8	M16 × 1.5	M14 × 1.5	0.24	6	1.50	38	0.75	19
-QDMFT-8mm-M16/M10	8	M16 × 1.5	M10 × 1	0.24	6	1.42	36	0.75	19
-QDMFT-8mm-M14/M16	8	M14 × 1.5	M16 × 1.5	0.24	6	1.50	38	0.87	22
-QDMFT-8mm-4/M14	8	NPT1/4	M14 × 1.5	0.24	6	1.50	38	0.75	19
-QDMFT-8mm-8/M14	8	NPT1/2	M14 × 1.5	0.24	6	1.69	43	0.87	22

● -QDTTF型压力表三通接头 Gauge Tee

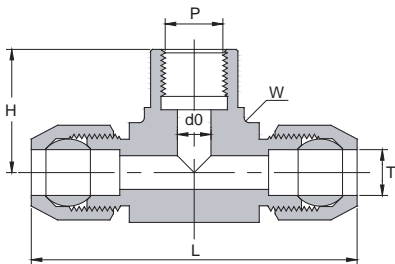

基本订货号 Order information	T (mm)	P	d0		L		H		W	
			英寸 (in)	毫米 (mm)	英寸 (in)	毫米 (mm)	英寸 (in)	毫米 (mm)	英寸 (in)	毫米 (mm)
-QDTTF-6mm-M10	6	M10 × 1	0.16	4	2.13	54	0.67	17	0.56	14.2
-QDTTF-6mm-M14	6	M14 × 1.5	0.16	4	2.24	57	0.83	21	0.75	19
-QDTTF-6mm-M20	6	M20 × 1.5	0.16	4	2.36	60	0.91	23	0.94	24
-QDTTF-8mm-M10	8	M10 × 1	0.24	6	2.17	55	0.67	17	0.56	14.2
-QDTTF-8mm-M14	8	M14 × 1.5	0.24	6	2.32	59	0.83	21	0.75	19
-QDTTF-8mm-M20	8	M20 × 1.5	0.24	6	2.44	62	0.91	23	0.94	24
-QDTTF-10mm-M10	10	M10 × 1	0.31	8	2.36	60	0.75	19	0.69	17.5
-QDTTF-10mm-M14	10	M14 × 1.5	0.31	8	2.44	62	0.83	21	0.75	19
-QDTTF-10mm-M20	10	M20 × 1.5	0.31	8	2.52	64	0.91	23	0.94	24
-QDTTF-10mm-G8	10	G1/2	0.31	8	2.52	64	0.91	23	0.94	24
-QDTTF-12mm-M14	12	M14 × 1.5	0.39	10	2.52	64	0.83	21	0.75	19
-QDTTF-12mm-M20	12	M20 × 1.5	0.39	10	2.52	64	0.91	23	0.94	24
-QDTTF-12mm-G8	12	G1/2	0.39	10	2.52	64	0.91	23	0.94	24

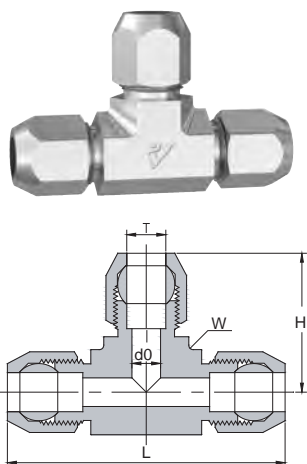

● -QD3型三通中间接头 Tee Union

基本订货号 Order information	T (mm)	d0		L		H		W	
		英寸 (in)	毫米 (mm)	英寸 (in)	毫米 (mm)	英寸 (in)	毫米 (mm)	英寸 (in)	毫米 (mm)
-QD3-3mm	3	0.08	2	1.81	46	0.83	23	0.37	9.5
-QD3-4mm	4	0.12	3	1.89	48	0.91	24	0.37	9.5
-QD3-6mm	6	0.16	4	2.05	52	0.98	26	0.50	12.7
-QD3-8mm	8	0.24	6	2.13	54	1.06	27	0.56	14.2
-QD3-10mm	10	0.31	8	2.28	58	1.18	29	0.69	17.5
-QD3-12mm	12	0.39	10	2.36	60	1.30	30	0.69	17.5

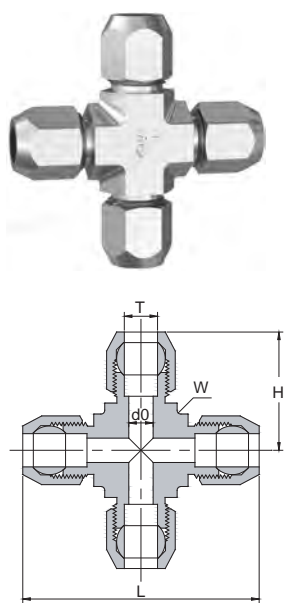

● -QD4型四通中间接头 Cross Union

基本订货号 Order information	T (mm)	d0		L		H		W	
		英寸 (in)	毫米 (mm)	英寸 (in)	毫米 (mm)	英寸 (in)	毫米 (mm)	英寸 (in)	毫米 (mm)
-QD4-3mm	3	0.08	2	1.81	46	0.83	23	0.37	9.5
-QD4-4mm	4	0.12	3	1.89	48	0.91	24	0.37	9.5
-QD4-6mm	6	0.16	4	2.05	52	0.98	26	0.50	12.7
-QD4-8mm	8	0.24	6	2.13	54	1.06	27	0.56	14.2
-QD4-10mm	10	0.31	8	2.28	58	1.18	29	0.69	17.5
-QD4-12mm	12	0.39	10	2.36	60	1.30	30	0.69	17.5

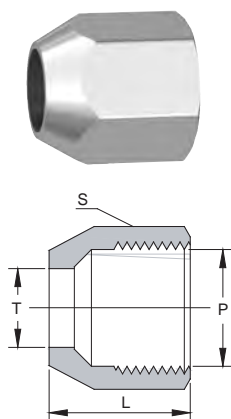

● -QD01型外套螺母 Cap Nut

基本订货号 Order information	T (mm)	P	L		S	
			英寸 (in)	毫米 (mm)	英寸 (in)	毫米 (mm)
-QD01-3mm	3	M8 × 1	0.39	10	0.39	10
-QD01-4mm	4	M8 × 1	0.43	11	0.39	10
-QD01-6mm	6	M10 × 1	0.55	14	0.47	12
-QD01-8mm	8	M12 × 1	0.55	14	0.55	14
-QD01-10mm	10	M14 × 1	0.63	16	0.67	17
-QD01-12mm	12	M16 × 1	0.67	17	0.75	19

XYG-QD系列铜制气动管接头

XYG — QD Copper pneumatic piping connector

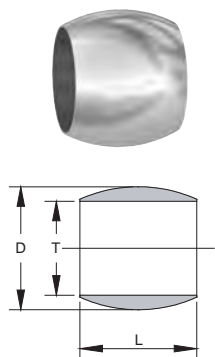

● -QD02型密封圈 Sealing Ring

基本订货号 Order information	T (mm)	D		L	
		英寸 (in)	毫米 (mm)	英寸 (in)	毫米 (mm)
-QD02-3mm	3	0.20	5	0.20	5
-QD02-4mm	4	0.24	6	0.24	6
-QD02-6mm	6	0.31	8	0.28	7
-QD02-8mm	8	0.39	10	0.28	7
-QD02-10mm	10	0.47	12	0.28	7
-QD02-12mm	12	0.55	14	0.31	8

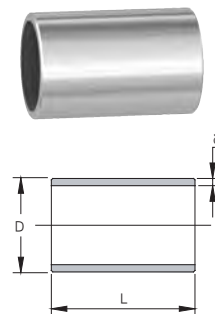

● -QD03型薄壁衬套 Thin Bushing

基本订货号 Order information	T (mm)	δ	L		D	
			英寸 (in)	毫米 (mm)	英寸 (in)	毫米 (mm)
-QD03-3mm	3	0.5	0.47	12	0.08	2
-QD03-4mm	4	0.5	0.55	14	0.12	3
-QD03-6mm	6	0.6	0.63	16	0.16	4
-QD03-8mm	8	0.6	0.67	17	0.24	6
-QD03-10mm	10	0.8	0.71	18	0.31	8
-QD03-12mm	12	1.0	0.79	20	0.39	10

● -QDFP系列铜制气动管路接头（塑料管用） Copper pneumatic piping connector (for plastic pipe)

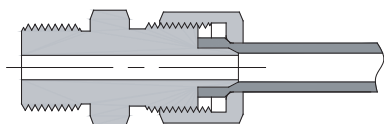

配管外径 T (mm)	公称压力 PN (Mpa)	公称通径 DN (mm)	适用介质 Med	适用温度 Temp	制造材料 Material
6	1	3	非腐蚀性气体	常温	H62表面镀铬
8		5	Non-Corrosive	Normal Temp	H62 (Cr surface)
10		7	Gas	Norm	Galvanization

● -QDFP1型直通终端接头 Straight Connector

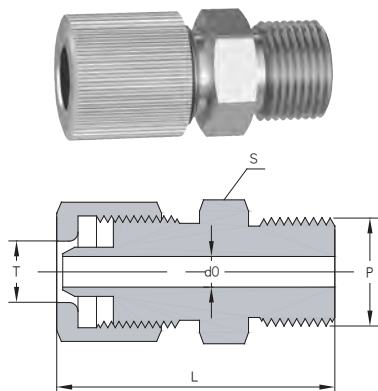

基本订货号 Order information	T (mm)	P	d0		L		S	
			英寸 (in)	毫米 (mm)	英寸 (in)	毫米 (mm)	英寸 (in)	毫米 (mm)
-QDFP1-6mm-M10	6	M10×1	0.12	3	1.42	36	0.55	14
-QDFP1-8mm-M16	8	M16×1.5	0.20	5	1.57	40	0.75	19
-QDFP1-10mm-M20	10	M20×1.5	0.28	7	1.73	44	0.94	24
-QDFP1-6mm-2	6	NPT1/8	0.12	3	1.42	36	0.47	12
-QDFP1-8mm-4	8	NPT1/4	0.20	5	1.50	38	0.55	14
-QDFP1-10mm-6	10	NPT3/8	0.28	7	1.65	42	0.67	17

● -QDFP7型内螺纹直通终端接头 Female Connector

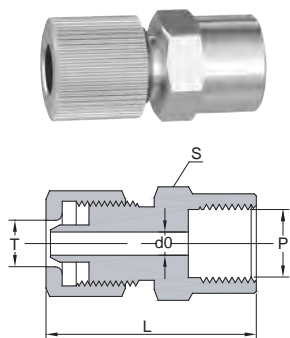

基本订货号 Order information	T (mm)	P	d0		L		S	
			英寸 (in)	毫米 (mm)	英寸 (in)	毫米 (mm)	英寸 (in)	毫米 (mm)
-QDFP7-6mm-M14	6	M14 × 1.5	0.12	3	1.57	40	0.75	19
-QDFP7-8mm-M16	8	M16 × 1.5	0.20	5	1.65	42	0.87	22
-QDFP7-10mm-M20	10	M20 × 1.5	0.28	7	1.73	44	0.94	24
-QDFP7-6mm-4	6	NPT1/4	0.12	3	1.57	40	0.67	17
-QDFP7-8mm-6	8	NPT3/8	0.20	5	1.65	42	0.87	22
-QDFP7-10mm-8	10	NPT1/2	0.28	7	1.73	44	1.06	27

● --QDFP6型直通中间接头 Straight Union

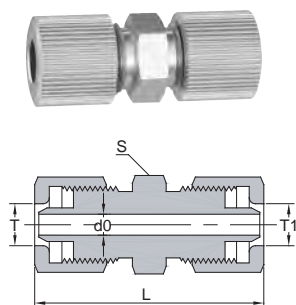

基本订货号 Order information	T (mm)	T1 (mm)	d0		L		S	
			英寸 (in)	毫米 (mm)	英寸 (in)	毫米 (mm)	英寸 (in)	毫米 (mm)
-QDFP7-6mm-6mm	6	6	0.12	3	1.77	45	0.47	12
-QDFP7-8mm-8mm	8	8	0.20	5	1.77	45	0.55	14
-QDFP7-10mm-10mm	10	10	0.28	7	1.93	49	0.67	17
-QDFP7-6mm-8mm	6	8	0.12	3	1.81	46	0.55	14
-QDFP7-6mm-10mm	6	10	0.20	3	1.89	48	0.67	17
-QDFP7-8mm-10mm	8	10	0.28	5	1.89	48	0.67	17

● -QDFP2型弯通终端接头 Elbow Connector

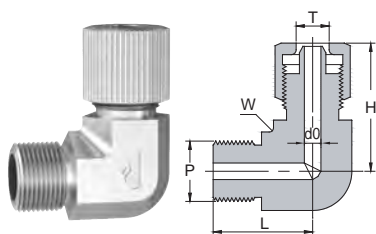

基本订货号 Order information	T (mm)	P	d0		L		H		W	
			英寸 (in)	毫米 (mm)	英寸 (in)	毫米 (mm)	英寸 (in)	毫米 (mm)	英寸 (in)	毫米 (mm)
-QDFP7-6mm-M10	6	M10 × 1	0.12	3	0.79	20	1.18	30	0.55	14
-QDFP7-8mm-M16	8	M16 × 1.5	0.20	5	0.91	23	1.18	30	0.75	19
-QDFP7-10mm-M20	10	M20 × 1.5	0.28	7	0.98	25	1.34	34	0.94	24
-QDFP7-6mm-2	6	NPT1/8	0.12	3	0.79	20	1.18	30	0.47	12
-QDFP7-8mm-4	8	NPT1/4	0.20	5	0.87	22	1.18	30	0.55	14
-QDFP7-10mm-6	10	NPT3/8	0.28	7	1.02	26	1.34	34	0.67	17

● -QDFP62型弯通穿板接头 Elbow Bulkhead

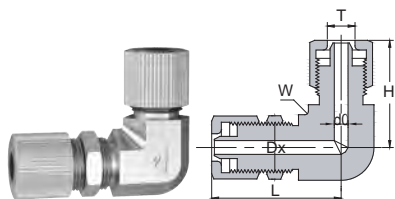

基本订货号 Order information	T (mm)	d0		L		H		W		Dx	
		英寸 (in)	毫米 (mm)	英寸 (in)	毫米 (mm)	英寸 (in)	毫米 (mm)	英寸 (in)	毫米 (mm)	英寸 (in)	毫米 (mm)
-QDFP62-6mm	6	0.12	3	1.65	42	1.18	30	0.55	14	0.41	10.5
-QDFP62-8mm	8	0.20	5	1.65	42	1.18	30	0.67	17	0.49	12.5
-QDFP62-10mm	10	0.28	7	1.81	46	1.34	34	0.75	19	0.57	14.4

XYG-QD系列铜制气动管接头

XYG — QD Copper pneumatic piping connector

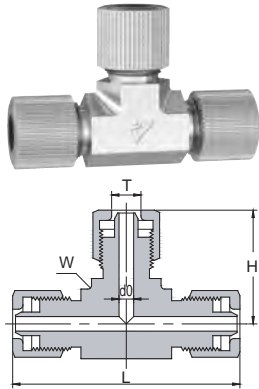

● -QDFP3型三通中间接头 Tee Union

基本订货号 Order information	T (mm)	d0		L		H		W	
		英寸 (in)	毫米 (mm)	英寸 (in)	毫米 (mm)	英寸 (in)	毫米 (mm)	英寸 (in)	毫米 (mm)
-QDFP3-6mm	6	0.12	3	2.28	58	1.14	29	0.55	14
-QDFP3-8mm	8	0.20	5	2.36	60	1.18	30	0.67	17
-QDFP3-10mm	10	0.28	7	2.60	66	1.34	34	0.75	19

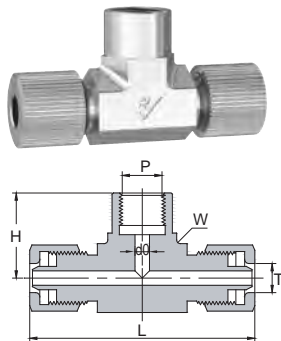

● -QDFPTFT型压力表三通接头 Gauge Tee

基本订货号 Order information	T (mm)	P	d0		L		H		W	
			英寸 (in)	毫米 (mm)	英寸 (in)	毫米 (mm)	英寸 (in)	毫米 (mm)	英寸 (in)	毫米 (mm)
-QDFPTFT-6mm-M10	6	M10×1	0.12	3	2.40	61	0.63	16	0.55	14
-QDFPTFT-8mm-M14	8	M14×1.5	0.20	5	2.52	64	0.75	19	0.75	19
-QDFPTFT-10mm-M20	10	M20×1.5	0.28	7	2.68	68	0.98	25	0.94	24

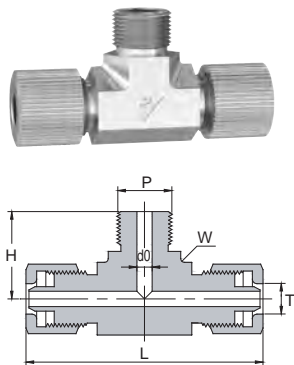

● -QDFPTMT型三通终端接头 Tee Connector

基本订货号 Order information	T (mm)	P	d0		L		H		W	
			英寸 (in)	毫米 (mm)	英寸 (in)	毫米 (mm)	英寸 (in)	毫米 (mm)	英寸 (in)	毫米 (mm)
-QDFPTMT-6mm-M10	6	M10×1	0.12	3	2.36	60	0.79	20	0.56	14.2
-QDFPTMT-8mm-M14	8	M14×1.5	0.20	5	2.48	63	0.91	23	0.69	17.5
-QDFPTMT-10mm-M20	10	M20×1.5	0.28	7	2.56	65	0.91	23	0.94	23.8
-QDFPTMT-6mm-2	6	NPT1/8	0.12	3	2.36	60	0.79	20	0.50	12.7
-QDFPTMT-8mm-4	8	NPT1/4	0.20	5	2.36	60	0.87	22	0.56	14.2
-QDFPTMT-10mm-8	10	NPT1/2	0.28	7	2.56	65	0.94	24	0.94	23.8

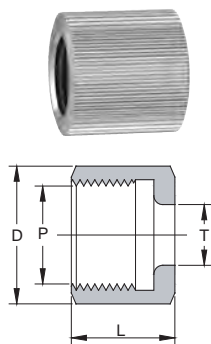

● -QDFP04型螺母 Nut

基本订货号 Order information	T (mm)	P	D		L	
			英寸 (in)	毫米 (mm)	英寸 (in)	毫米 (mm)
-QDFP04-6mm	6	M10×1	0.51	13	0.51	13
-QDFP04-8mm	8	M12×1	0.63	16	0.51	13
-QDFP04-10mm	10	M14×1	0.75	19	0.59	15

SINYA

港商 扬中新亚自控工程有限公司
独资 YANGZHONG SINYA AUTO-CONTROL ENGINEERING CO., LTD.

地址：江苏省扬中经济开发区兴隆港北路

Add: Xinglong Port, Yangzhong, Zhenjiang, Jiangsu, China

电话(Tel): 0511-88783806

传真(Fax): 0511-88451691

网址(Http): www.sklok.com

邮箱(E-mail): sales@sklok.com info@sklok.com